



微信公众账号



FACEBOOK

安徽长庚光学科技有限公司

www.laowalens.com

服务热线:400-066-1316

Email: sales@laowalens.com

电话Tel:(+86) 0551-69107990

地址:合肥市庐阳区天水路6号

Add:Tianshui Road, Luyang District,Hefei City, Anhui Province, China

CF 65mm F2.8

CA-Dreamer Macro 2X

使用手册
Instruction Manual

LAOWA 老蛙

本公司保留更改产品设计与规格的权利, 届时恕不另行通知;
本公司保留对此《使用说明》的最终解释权。
Please note we reserve the right to change our product's
design and specifications at any time without notice and
to the final interpretation of the *Instruction Manual*.



前言

真诚地感谢您选购LAOWA CF 65mm F2.8 CA-Dreamer Macro 2X微距镜头。此镜头是无反半画幅画幅系统镜头，支持微距模式下最大2倍放大，并且拥有“APO”复消色差技术，从无穷远到微距，都提供了极佳的成像画质，为用户提供了稳定可靠的支持。可拍摄到微小的物体，如小型昆虫、珠宝首饰等。

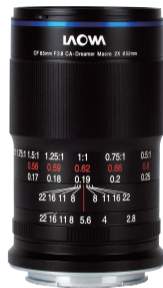

△ 为了操作上的安全，使用本产品前请务必仔细阅读使用手册与注意事项，并将手册放在需要时容易取得的地方。如遇到不能解决的问题请通过售后电话获取技术支持。

主要特色

- LAOWA CF 65mm F2.8 CA-Dreamer Macro 2X 区别于传统的微距镜头，此款镜头在无反半画幅画幅系统的高性能成像基础上，无穷远到微距都可以拍出高解析画质的照片，并且微距模式下达到了令人惊叹的2倍物体放大，此款镜头拥有“APO”复消色差技术，在2倍放大倍率下，也没有明显的色散。更高的放大倍率，使用户拥有更多的创作空间。
- 镜头采取迷你化设计，大小仅有 $\phi 57\text{mm} \times 100\text{mm}$ ，重量335g，搭配在无反半画幅机身上使用，体积小，轻便携带。
- 内部有10组14枚镜片，包含3枚异常分散玻璃结构带来的高素质成像。外有全金属材料制成的机械结构，保障了镜头长期使用的耐用性。
- 此款镜头采用全封闭设计，不易进灰，减少后期的清理维护工作。

注意事项

△ 安全注意事项

- 切勿自行拆解、修改或改装。当产品由于外力原因破损，切勿触碰外露部分或破损边缘处。
- 切勿放置于直射阳光下、封闭车辆中或其余高温处，否则过高的温度会使镜片和其他部件产生伸缩变形。
- 不使用镜头时，请将镜头前盖盖上或置于没有阳光照射处。凸透镜反射出的光线可能会聚集在附近物体上，导致发生火灾。
- 在逆光拍摄时，切勿将太阳置于画面中心，应该使太阳充分偏离画角，否则阳光会在相机内部聚集并导致火灾或灼伤眼睛。
- 在使用相机内置闪光灯拍摄时，由于镜头本身会遮挡光线而产生渐晕，因此建议您使用外设闪光灯拍摄。
- 本镜头为无反半画幅画幅系统镜头，装在全画幅相机上时，镜头画面视角将有黑角，需要调整为无反半画幅拍摄模式。

注意事项

■ 长期使用保养注意事项

- 避免触摸镜头表面,应用专用镜头布或气吹去除镜头表面的尘埃,不使用镜头时,应将镜头盖盖上。
- 使用镜头纸或镜头布清洁时,以螺旋的方式从中间向外擦拭镜头上的污垢以及指印。
- 镜头从寒冷的环境突然转移至温暖的环境时,镜头的外部以及内部镜片将会凝结水雾,所以在转移时应采取防潮保护措施。

各部件名称

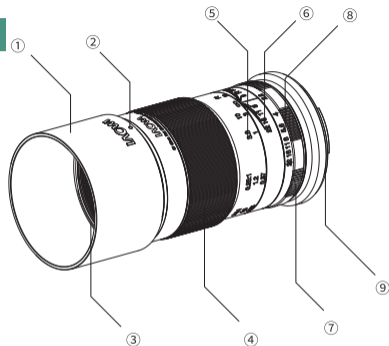

- | | | |
|-----------|-----------|---------|
| ①遮光罩 | ④对焦环 | ⑦光圈环 |
| ②遮光罩安装标记 | ⑤距离(倍率)刻度 | ⑧光圈刻度 |
| ③滤镜(镜头盖)安 | ⑥景深指示刻度 | ⑨镜头安装标记 |

■ 镜头安装

- 取下镜头后盖,将镜头卡口上的安装标记⑨对准相机座圈上的对应标记,随后将镜头插入机身座圈,根据所购买卡口的安装方向旋转镜头,直至咔嚓声锁紧镜头。安装时请不要用力过猛,以免导致卡口损伤。

■ 镜头拆卸

- 关机后按住相机上的镜头释放按钮,依照所购买卡口的安装方向反向旋转镜头,随后将镜头从座圈中拔出。
- 装上镜头后,请尝试旋转镜头确认是否已将其固定在相机上。

■ 遮光罩装卸

- 将遮光罩上的安装标记②对准镜头上的遮光罩安装点,然后顺时针旋转遮光罩,直至锁紧末端为止。
- 如要拆卸遮光罩,按相反方向旋出即可。
- 安装遮光罩可减少强光并保护镜头前部元件。
- 安装某些滤光镜后,您可能无法再使用遮光罩。
- 若不使用遮光罩时,可将遮光罩反向安装于镜头上。
- 利用闪光灯拍摄时,遮光罩可能遮挡住光线而造成影像上的渐晕现象。所以在使用相机闪光灯或使用高度不够的外置闪光灯时,请拆卸遮光罩后再进行拍摄。或安装微距专用环形闪光灯。

■ 对焦

- 此款镜头是全手动对焦镜头,合焦时,缓慢旋转对焦环④,直至合焦。
- 不要过猛过快地旋转对焦环,避免用力过度损坏对焦环部件。
- 镜头上的距离刻度⑤与景深刻度⑥是出于指导目的。实际焦点与最深可能同刻度标记稍有不同。
- 如需要非常精确的对焦,请在固定好相机位置的情况下使用最大光圈对焦,对焦完成后,再旋至所需要的光圈值。
- 为了对焦的方便性,请开启相机内的峰值对焦功能(视所使用相机功能而定)。

使用说明

■ 光圈使用

- 光圈在镜头上调节,根据拍摄环境和与所需要的景深,转动光圈环⑦来选择对应的光圈。
- 由于此镜头无CPU数据,所以暂时无法记录光圈参数。
- 由于光圈为手动调节,无法较好的使用快门优先模式,但可以使用光圈优先模式(测光准确度视相机型号而定)。

■ 微距摄影模式

- 最大放大倍率为2:1倍,最近对焦距离为17cm,从被拍物体镜头第一片玻璃的最近距离约5.8cm。

使用说明

■ 对焦方法

对焦方法一:

放大倍率预先确定后再进行对焦

- ① 预先确定放大倍率,随后转动对焦环至所需的放大倍率刻度。
- ② 通过取景器或开启Live View(实时取景)功能观察画面,并前后平移相机进行粗略对焦直至确定合适的焦距。

对焦方法二:

先构定拍摄画面 在通过取景器或开启Live View(实时取景)功能观察画面的同时,转动对焦环,构定拍摄画面后,进行方法一的②、③步骤。

- 在进行高放大倍率拍摄时,镜头的工作距离非常短,容易碰到拍摄物体,请小心拍摄。
- 放大倍率是指记录在传感器或胶片上的图像尺寸大小与拍摄物体的实际尺寸大小之间的比例关系。

FNo.	无限远		0.25倍	
	back	front	back	front
2.8	INF	68390.86	1059.48	368.65
4	INF	49617.52	1063.67	368.52
5.6	INF	35121.26	1071.47	367.94
8	INF	24870.85	1082.73	367.13
11	INF	17622.72	1099.11	366
16	INF	12497.51	1123.27	364.41

0.5倍		0.75倍	
back	front	back	front
242.96	242.2	203.38	202.99
243.08	242.09	203.4	202.96
243.29	241.88	203.5	202.87
243.59	241.59	203.63	202.74
244.01	241.19	203.81	202.56
244.61	240.62	204.08	202.31

1倍		1.25倍		1.5倍	
back	front	back	front	back	front
185.84	185.59	177.09	176.91	172.71	172.57
185.89	185.54	177.12	176.89	172.72	172.56
185.97	185.47	177.16	176.84	172.75	172.53
186.07	185.37	177.23	176.78	172.79	172.48
186.22	185.23	177.32	176.69	172.86	172.42
186.43	185.02	177.46	176.56	172.95	172.33

1.75倍		2倍	
back	front	back	front
170.79	170.68	170.39	170.29
170.79	170.68	170.4	170.27
170.82	170.65	170.43	170.25
170.85	170.62	170.47	170.21
170.9	170.57	170.53	170.16
170.97	170.51	170.6	170.08

规格表

CF 65mm F2.8 CA-Dreamer Macro 2X	
镜头型号	CF 65mm F2.8 CA-Dreamer Macro 2X
画幅	无反半画幅
焦点距离	65mm
最大光圈	F2.8
视场角	24.4°
镜头结构	10组14枚(3枚异常分散玻璃)
光阑叶片	9片
最小光圈	F22
最近摄影距离(物像距离)	17cm
最大放大倍率	2倍
合焦驱动方式	手动(MF)
滤镜尺寸	ø52mm
镜头尺寸	约ø57mm*100mm
重量	约335g
卡口	E、X、EF-M、RF、Z

镜片结构

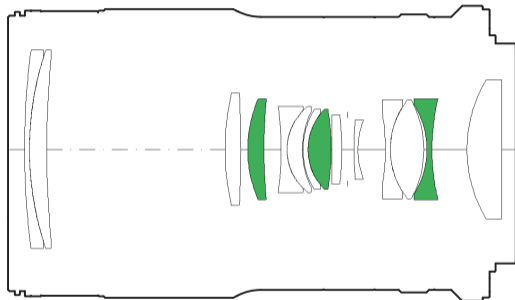

● 异常分散玻璃

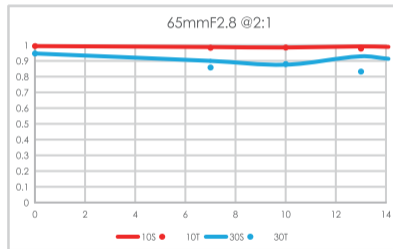
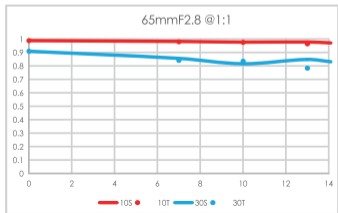
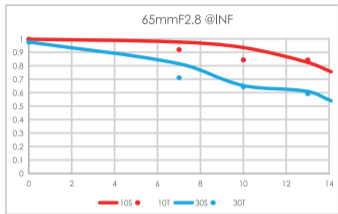

老蛙镜头

新创意·新乐趣





PREFACE

Thank you very much for purchasing LAOWA CF 65mm F2.8 CA-Dreamer Macro 2X Lens. This lens can cover the mirrorless APS-C sensor size and provide 2:1 magnification. This lens also features an apochromatic (APO) design. It delivers a crystal sharpness image from 2:1 magnification to infinity. It allows photographers to capture subjects at small sizes, like small insects and jewelry.

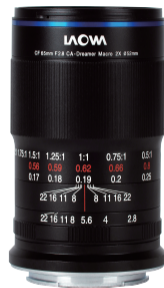

△ Read this operation manual carefully to familiarize yourself with its contents and ensure that you can operate the product properly. Keep the Instruction Manual in a safe place where it can easily be referenced whenever required. If you are still unable to solve the problem by reading the manual, please contact our after-sales service for further technical support.

FEATURES

- LAOWA CF 65mm F2.8 CA-Dreamer Macro 2X lens is different from the traditional macro lens. Based on the high-performance of the mirrorless APS-C system, this lens delivers high-resolution images from macro to infinity and achieves 2:1 magnification when shooting macro. This lens features an apochromatic (APO) design. No visible chromatic aberration even at 2:1 magnification. The wider magnification range allows more creative space for users.
- This lens only has $\phi 57\text{mm} \times 100\text{mm}$ and weighs 335g. The tiny size and lightweight match perfectly with the mirrorless cameras.
- The 14 elements in 10 groups optics design, which including 3 extra-low dispersion elements, delivers high image quality. Housing full metal, which ensures long-term usage.
- This lens adopts the fully enclosed design, which is not easy to enter dust and reduces the cleaning and maintenance work in the later stage.

PRECAUTIONS

Safety Precautions

- Do not disassemble, modify the lens by yourself. Do not touch the internal parts that become exposed as the result of external force.
- Do not leave the lens where it will be exposed to high temperatures, such as in direct sunlight and an enclosed vehicle. Excessive heat may deform the glass elements and other parts of the lens.
- Do not leave the lens under the sun. If sunlight is focused on a nearby object, it may cause a fire. Keep the lens cap attached when it's not in use.
- Do not place the sun in the frame center when shooting with backlight. Doing so might cause a fire or harm your eyes.
- The camera's built-in flash will cause barrel shadow if used with this lens. For best results, please only use an external flash unit.
- Because this lens is designed for mirrorless APS-C cameras system, vignetting will occur when mounted on full format cameras. Make sure that you switch to mirrorless APS-C shooting mode when mounting this lens on full format cameras.

PRECAUTIONS

■ Maintenance Precautions

- Do not touch the lens contacts. Clean by a lens cloth or a blower. Always place the lens cap on the lens when storing.
- Try a circular motion from the center outward when using a lens tissue or a cleaning cloth to remove oil, fingerprints, and grime on the lens surface.
- If your lens is brought directly from a cold place to a warm place, condensation may appear on the lens. To avoid this, be sure to take some action to protect the lens.

NOMENCLATURE

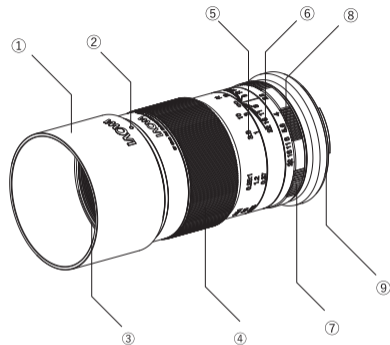

- ① Lens hood
- ② Lens hood mounting index
- ③ Filter (lens cap) mounting thread

- ⑤ Distance (magnification) scale
- ⑥ Depth of field scale
- ⑦ Aperture ring
- ⑧ Aperture scale
- ⑨ Lens mounting index

INSTRUCTIONS

■ To attach the Lens

- Remove the rear lens cap. Align the mounting index on the lens bayonet with the mounting index on the camera, then insert the lens into the camera mount and rotate it in the direction for your lens version until it locks. Do not use excessive force during installation to avoid damage to the bayonet.

■ To remove the lens

- Turn the camera off. While pressing and holding the lens release button on the camera, rotate the lens in the reverse direction for attaching the lens until it stops, then detach the lens.
- After attaching the lens, please try to rotate the lens to make sure it mounted onto the camera properly.

INSTRUCTIONS

■ Attaching/detaching lens hood

- Align the mounting index on the lens hood and the lens. Turn the hood clockwise until it locks.
- For detaching lens hood, rotate it counterclockwise.
- It is recommended that you use a lens hood to reduce strong light and protect the front element.
- Lens hood may be unavailable when using certain filters.
- When storing, turn over the lens hood and place it onto the lens backward.
- When shooting with a flash, the lens hood may block light and cause vignetting. So when shooting with the camera's built-in flash or with the external flash unit that is not high enough, please remove the hood before shooting. Selecting a dedicated macro ring flash is also a great option.

■ Focusing

- This is a fully manual lens. Rotate the focusing ring^④ slowly to get focus.
- Turn the focus ring slowly and gently to prevent the focus mechanism from damage.
- The distance scale^⑤ and depth of field scale^⑥ are for instructional purposes. Actual focus and DOF may slightly differ from those scale indications.
- To get precise focus, it is recommended to focus wide open when the camera position is fixed. Get focus first, then set the desired aperture by turning the aperture ring.
- Turn on the focus peaking on the camera to help focusing. (Note that the function depends on camera models.)

INSTRUCTIONS

■ Setting the Aperture

- According to the shooting situation and desired depth of field, rotate the aperture ring ⑦ on the lens to the corresponding aperture.
- This lens cannot provide actual aperture value to the camera since there's no CPU data.
- Aperture-priority is a better option than Shutter-priority for the lens because of its manual aperture. (Note that metering precision depends on the camera models.)

■ Macro Shooting

- This lens features 2:1 magnification. The minimum focus distance is 17cm. The minimum distance between the subject and the first glass of the lens is about 5.8cm.

INSTRUCTIONS

■ Focusing Tips

Method 1 Magnification Priority

- ① Set the magnification first, and then turn the focus ring to the desired magnification mark on the lens.
- ② Check the frame by viewfinder or [Live View] on the camera and try to get focus by moving the camera back and forth until obtaining the proper focal length.
- ③ Rotate the focus ring to achieve precise focus.

Method 2 Framing Priority

Set the frame first. Turn the focus ring while you are checking the image through viewfinder or [Live View] on the camera, and then follow steps 2, 3 as the method 1 above.

- *For high magnification close-ups, because of the extremely short working distance, please be careful not to touch the subject.*
- *Magnification refers to the proportional relationship between the size of an image recorded on a sensor or film and the actual size of the subject.*

DEPTH OF FIELD

FNo.	Infinity		0.25x	
	back	front	back	front
2.8	INF	68390.86	1059.48	368.65
4	INF	49617.52	1063.67	368.52
5.6	INF	35121.26	1071.47	367.94
8	INF	24870.85	1082.73	367.13
11	INF	17622.72	1099.11	366
16	INF	12497.51	1123.27	364.41

0.5x		0.75x	
back	front	back	front
242.96	242.2	203.38	202.99
243.08	242.09	203.4	202.96
243.29	241.88	203.5	202.87
243.59	241.59	203.63	202.74
244.01	241.19	203.81	202.56
244.61	240.62	204.08	202.31

1x		1.25x		1.5x	
back	front	back	front	back	front
185.84	185.59	177.09	176.91	172.71	172.57
185.89	185.54	177.12	176.89	172.72	172.56
185.97	185.47	177.16	176.84	172.75	172.53
186.07	185.37	177.23	176.78	172.79	172.48
186.22	185.23	177.32	176.69	172.86	172.42
186.43	185.02	177.46	176.56	172.95	172.33

1.75x		2x	
back	front	back	front
170.79	170.68	170.39	170.29
170.79	170.68	170.4	170.27
170.82	170.65	170.43	170.25
170.85	170.62	170.47	170.21
170.9	170.57	170.53	170.16
170.97	170.51	170.6	170.08

SPECIFICATIONS

CF 65mm F2.8 CA-Dreamer Macro 2X	
Lens No.	CF 65mm F2.8 CA-Dreamer Macro 2X
Format	mirrorless APS-C
Focal Distance	65mm
Max. Aperture	F2.8
Angle of View	24.4°
Lens Construction	14 elements/ 10 groups (ED glass x3)
Aperture Blades	9
Min. Aperture	F22
Min. Shooting Distance	17cm
Max. Magnification	2x
Focusing	MF
Filter Thread	ø52mm
Dimensions	ø57mm*100mm
Weight	335g
Mounts	E、X、EF-M、RF、Z

LENS CONSTRUCTION

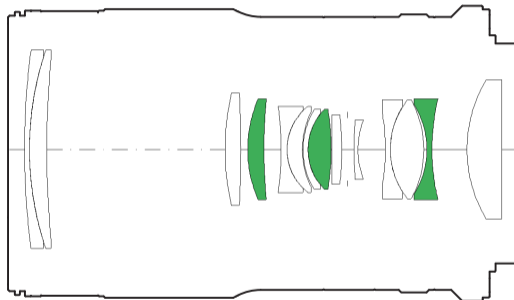

● Extra-low Dispersion Glass

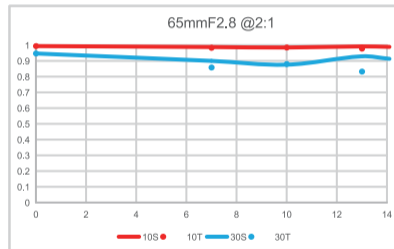
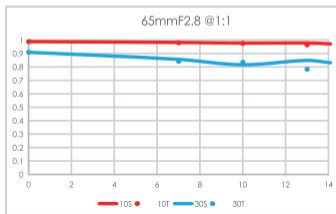
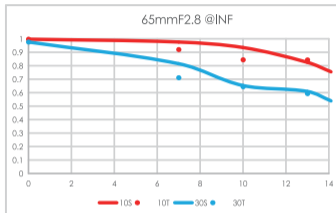

LAOWA

NEW IDEA . NEW FUN.